

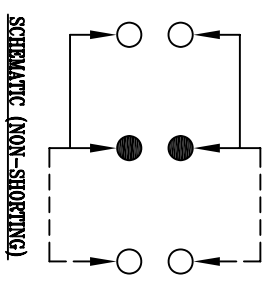

CAD FILE :

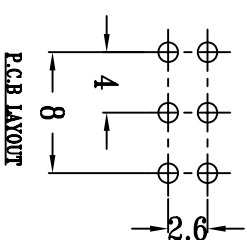
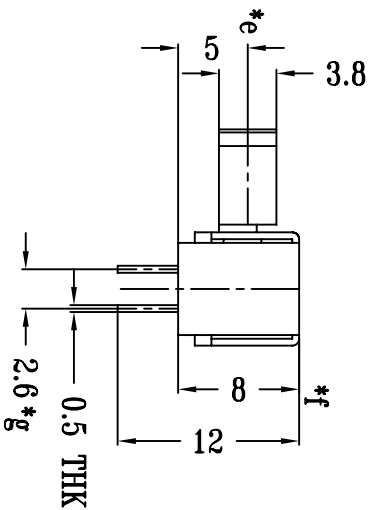
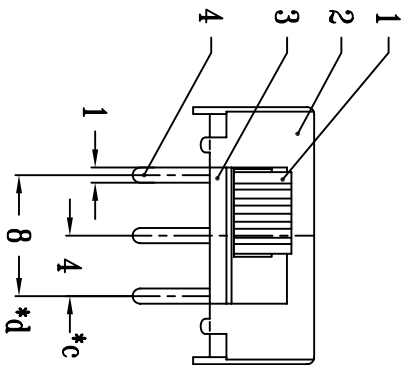
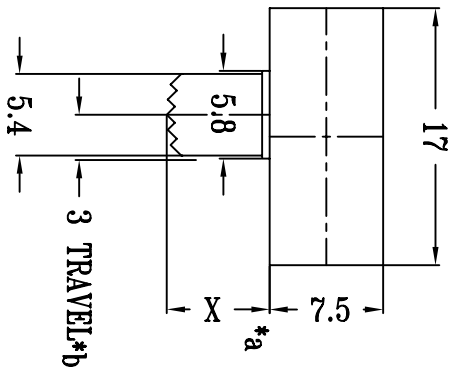

SCHEMATIC (NON-SHORTING)

注:带*表示关键尺寸(7个)

8																			
7																			
6	CONTACT	COPPER STRIP	2	Ag PLATED	TOLERANCE UNLESS SPECIFIED		SHENZHEN XIEJIA ELECTRONICS CO.,LTD.												
5	SPRING	STEEL WIRE	2	TEMPER	WITHIN: 1.5 ±0.1mm	ISSUE	DATE	DESCRIPTIONS	APPD										
4	TERMINAL	BRASS STRIP	6	Ag PLATED OVER NI PLATED	OVER: 1.5 ±0.2mm	TITLE: HORIZONTAL SLIDE SWITCH		UNIT : M M											
3	TERMINAL BASE	PHENOLIC RESIN	1	BLACK	MODEL: SK-22F01		SCALE : 2:1	DRWG NO :XJ-DR-SK22F01-00	DWN. ZHOUYU	2002-9-25									
2	FRAME	STEEL STRIP	1	NI PLATED	ALL MATERIALS MUST BE COMPLIANT TO ROHS			CHK'D FANGYING	2002-9-25										
1	KNOB	POM	1	BLACK				APPD. KANGXINAN	2002-9-25										
NO.	PART NAME	MATERIAL	QTY.	FINISHING															